



YLI ELECTRONIC

# Mortise Mount Magnetic Lock



## Specification

MODEL	SIZE(UNIT:MM)	VOLTAGE	CURRENT	HOLDING FORCE	DOOR
YM-180M	190Lx32Wx22.5H	12/24VDC	12V/300mA 24V/150mA	180kg(350Lbs)	Single Door
YM-180M-S	190Lx32Wx22.5H	12/24VDC	12V/300mA 24V/150mA	180kg(350Lbs)	Single Door
YM-280M	232Lx42Wx24.5H	12/24VDC	12V/500mA 24V/250mA	280kg(600Lbs)	Single Door
YM-280M-S	232Lx42Wx24.5H	12/24VDC	12V/500mA 24V/250mA	280kg(600Lbs)	Single Door
YM-500M	254Lx65.8Wx39H	12/24VDC	12V/420mA 24V/210mA	500kg(1200Lbs)	Single Door
YM-500M-S	254Lx65.8Wx39H	12/24VDC	12V/420mA 24V/210mA	500kg(1200Lbs)	Single Door

## Installation

### For example: YM-280M (Unit:mm)

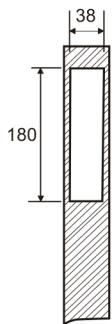

(1) Dig the hole

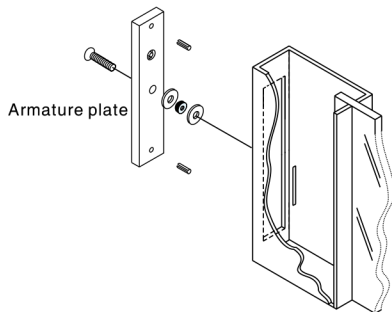

(2) Fix screws

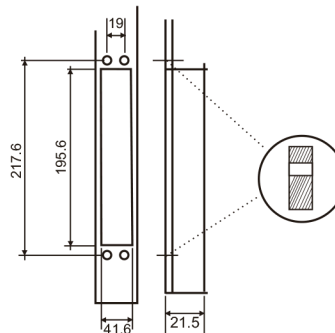

(3) Dig the hole

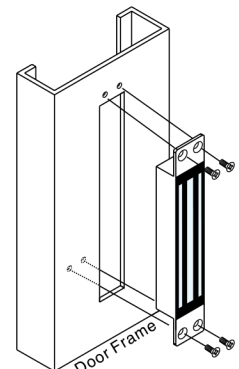

(4) Fix screws

### NOTES:

Please read specification before installing magnetic lock

- A. Handle the equipment carefully. The holding force can be reduced by damaging the lock body or armature plate.
- B. The magnetic lock should be fixed tightly on the door frame and the armature plate on the door leaf. Kit provided allows the armature plate to pivot its center, thus compensating misalignment caused by other factors.
- C. Template can only be used with the door in normally closed circumstance.
- D. Please fix screws of magnetic lock firmly.
- E. Detect signal of door state: the limit of reed switch and dry contact is 0.5A/30VDC. Don't overload.

**We create security**

## Circuit board diagram

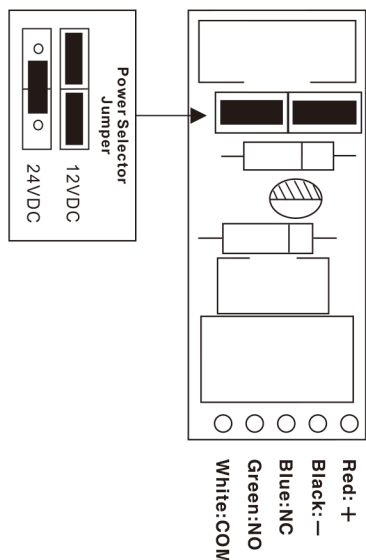

YM-180M-S

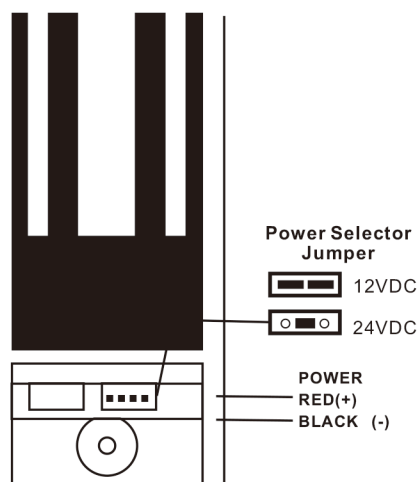

YM-180M, YM-280M, YM-500M

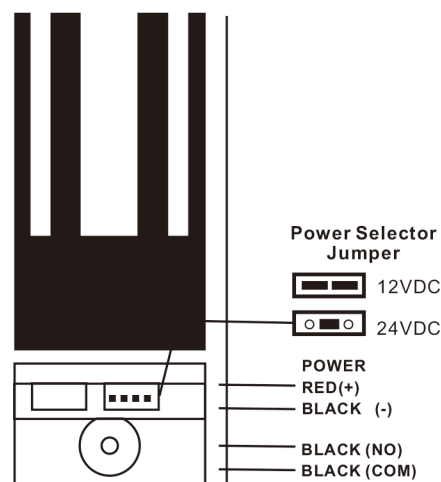

YM-280M-S, YM-500M-S

## Wire Connection

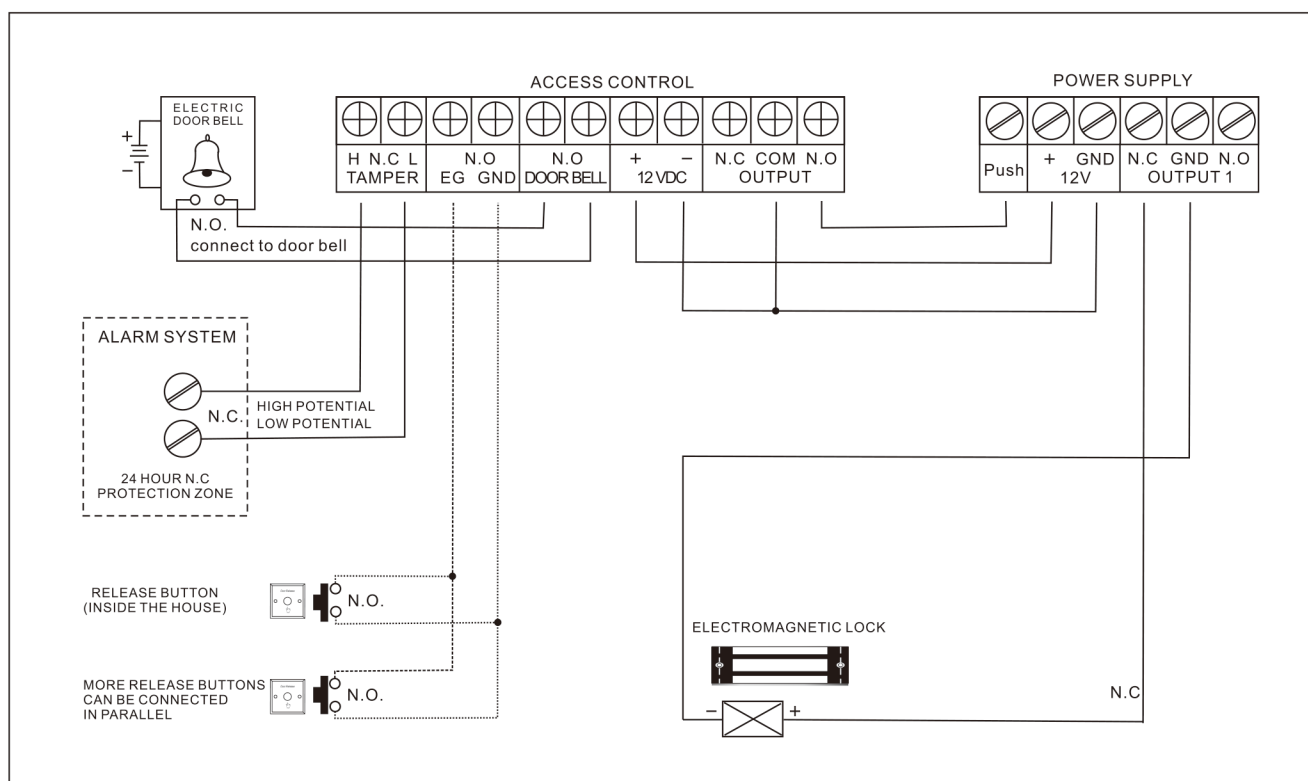

### ⚠ Cautions:

- The screw of armature plate should not be fixed too tight. Proper elasticity should be guaranteed for the rubber ring so that the armature plate can adjust itself to the appropriate position.
- Check the jumper's position before connecting. Figure out it represents 12VDC or 24VDC.