

# EW-SFP-GFE

## 1.25Gbps SFP to RJ45 Optical Transceiver DDM

EWIND



- Up to 1.25 Gb/s bi-directional data links;
- Hot-pluggable SFP footprint;
- Low power dissipation (1.05W typical);
- Low power dissipation (1.05W typical);
- Fully metal enclosure, for lower EMI;
- 10/100/1000 BASE-T operation in host systems with SGMII interface;
- Single +3.3V power supply;
- 1.25 Gigabit Ethernet over Cat 5 cable;
- Ambient Operating temperature: 0°C to +70°C.

**RoHS** **FC** **CE**

### 1: APPLICATION

EW-SFP-GFE are based on the SFP Multi Source Agreement (MSA) . They are compatible with the Gigabit Ethernet and 10/100/1000BASE-T standards as specified in IEEE Std 802.3.

The EW-SFP-GFE uses the SFP's RX\_LOS pin for link indication. If pull up SFP's TX\_DISABLE pin, PHY IC be reset.

### 2: TECHNICAL SPECIFICATION

Parameter	Symbol	Minimum	Typical	Maximum	Units
<b>Absolute Maximum Ratings</b>					
Supply Voltage	Vcc	0	-	+3.6	V
Operating Relative Humidity	RH	5	-	95	%
<b>Operation Environment</b>					
Supply Voltage	Vcc	3.15	3.3	3.45	V

Operating Case Temperature	Tc	0		+70	
Power Dissipation				1	W
Data Rate			1.25		Gbps
<b>Optical Characteristics</b>					
<b>Transmitter Section</b>					
Center Wavelength	$\lambda_o$	1260	1310	1360	nm
Average Output Power	$\Delta\lambda$	-	-	4	nm
Extinction Ratio	Po	-9	-	-3	dBm
Rise/Fall Time(20%~80%)	Er	8	-		dB
Total jitter	Tr/Tf			300	ps
Optical Eye Diagram	IEEE 802.3z and ANSI Fibre Channel Compatible				
<b>Receiver Section</b>					
Center Wavelength	$\lambda_o$	1260		1620	nm
Receiver Sensitivity	Rsen			-22	dBm
Receiver Overload	Rov	-3			dBm
Return Loss		12			dB
LOS Assert	LOSA	-36			dBm
LOS Dessert	LOSD			-23	dBm
LOS Hysteresis		0.5		5	
<b>Electrical Characteristics</b>					
<b>Transmitter Section</b>					
Input Differential Impendence	Zin	90	100	110	Ohm
Data Input Swing Differential	Vin	500		2400	mV
TX Disable	Disable		2.0	Vcc	V
	Enable		0	0.8	V
TX Fault	Assert		2.0	Vcc	V
	Deassert		0	0.8	V

Receiver Section						
Output differential impedance		Zout	-	100	-	Ohm
Data Input Swing Differential		Vout	370	-	2000	mV
Rx_LOS	Assert	-	2.0	-	Vcc	V
	Deassert	-	0	-	0.8	V

Add.	Field Size (Bytes)	Name of Field	HEX	Description
<b>EEPROM INFORMATION (A0)</b>				
0	1	Identifier	03	SFP
1	1	Ext. Identifier	04	MOD4
2	1	Connector	07	LC
3-10	8	Transceiver	00 00 00 02 12 00 0D 01	Transmitter Code
11	1	Encoding	01	8B10B
12	1	BR, nominal	0D	1250M bps
13	1	Reserved	00	
14	1	Length (9um)-km	14	20km
15	1	Length (9um)	64/C8/FF	
16	1	Length (50um)	00	
17	1	Length (62.5um)	00	
18	1	Length (copper)	00	
19	1	Reserved	00	
20-35	16	Vendor name	57 49 4E 54 4F 50 20 20 20 20 20 20 20 20 20 20	EWIND
36	1	Reserved	00	

37-39	3	Vendor OUI	00 00 00	
40-55	16	Vendor PN	XX XX XX XX XX XX XX XX XX XX XX XX XX XX XX XX	ASC II
56-59	4	Vendor rev	31 2E 30 20	V1.0
60-61	2	Wavelength	05 1E	1310nm
62	1	Reserved	00	
63	1	CC BASE	XX	Check sum of byte 0~62
64-65	2	Options	00 1A	LOS, TX_DISABLE, TX_FAULT
66	1	BR, max	32	50%
67	1	BR, min	32	50%
68-83	16	Vendor SN	00 00 00 00 00 00 00 00 00 00 00 00 00 00 00 00	Unspecified
84-91	8	Vendor date code	XX XX XX 20	Year, Month, Day
92-94	3	Reserved	00	
95	1	CC_EXT	XX	Check sum of byte 64~94
96-255	160	Vendor specific		

Parameter	Range	Accuracy	Unit	Calibration
<b>Diagnostics</b>				
Temperature	0 ~ 70	±5	°C	Internal
Voltage	3.15 ~ 3.45	0.1	V	Internal
Bias Current	10 ~ 80	±2	mA	Internal
Tx Power	-9 ~ -3	±2	dBm	Internal

Rx Power	-26~-3	±3	dBm	Internal
----------	--------	----	-----	----------

Pins	Name	Description	NOTE
<b>SFP to Host Connector Pin Out</b>			
1	VEET	Transmitter Ground (Common with Receiver Ground)	1
2	TFAULT	Transmitter Fault. Not supported.	
3	TDIS	Transmitter Disable. Laser output disabled on high or open.	2
4	MOD_DEF(2)	Module Definition 2. Data line for Serial ID.	3
5	MOD_DEF(1)	Module Definition 1. Clock line for Serial ID.	3
6	MOD_DEF(0)	Module Definition 0. Grounded within the module.	3
7	Rate Select	No connection required	
8	LOS	Loss of Signal indication. Logic 0 indicates normal operation.	
9	VEER	Receiver Ground (Common with Transmitter Ground)	1
10	VEER	Receiver Ground (Common with Transmitter Ground)	1
11	VEER	Receiver Ground (Common with Transmitter Ground)	1
12	RD-	Receiver Inverted DATA out. AC Coupled	
13	RD+	Receiver Non-inverted DATA out. AC Coupled	
14	VEER	Receiver Ground (Common with Transmitter Ground)	1

15	VCCR	Receiver Power Supply	
16	VCCT	Transmitter Power Supply	
17	VEET	Transmitter Ground (Common with Receiver Ground)	1
18	TD+	Transmitter Non-Inverted DATA in. AC Coupled.	
19	TD-	Transmitter Inverted DATA in. AC Coupled.	
20	VEET	Transmitter Ground (Common with Receiver Ground)	1

Notes:

1. Circuit ground is connected to chassis ground
2. PHY disabled on TDIS > 2.0V or open, enabled on TDIS < 0.8V
3. Should be pulled up with 4.7k - 10k Ohms on host board to a voltage between 2.0 V and 3.6 V. MOD\_DEF(0) pulls line low to indicate module is plugged in.

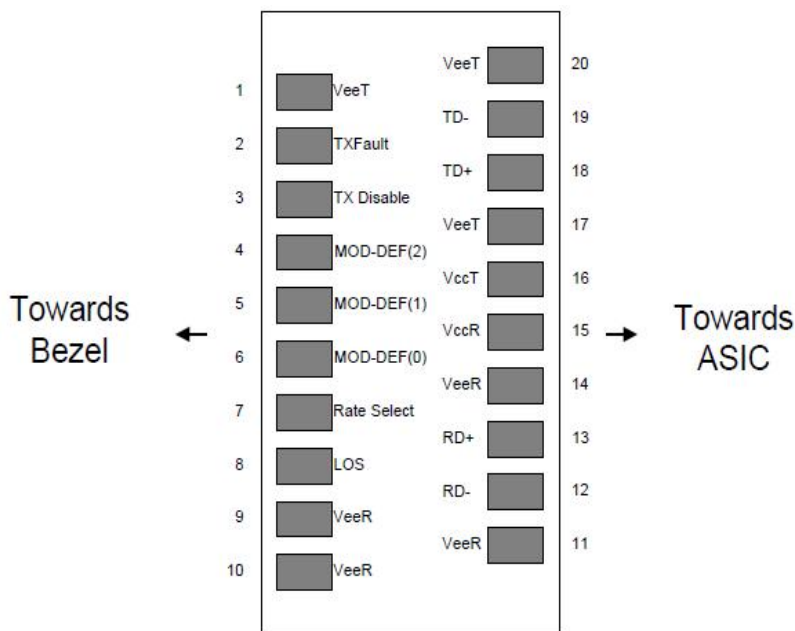
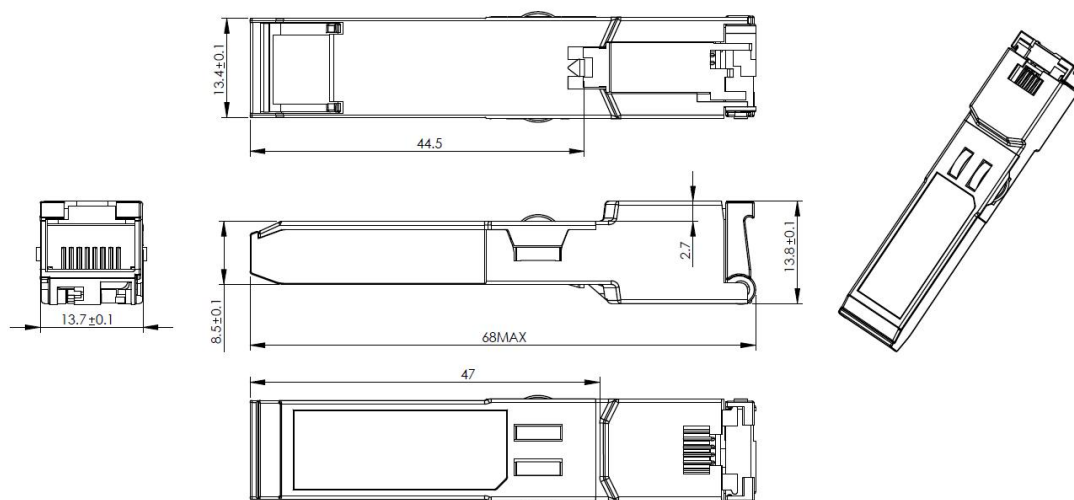

Figure 1. Diagram of host board connector block pin numbers and name.

#### 4: Outline drawing (mm)



#### 5: ORDER INFORMATION

Model	Description	Units
EW-SFP-FE-MD850	155M, Multi-mode Dual Fiber, 850nm, 550meter, LC connector;	1PCS
EW-SFP-FE-SD1310	155M, Single-mode Dual Fiber, 1310nm, 20km, LC connector;	1PCS
EW-SFP-GE-MD850	1.25G, Multi-mode Dual Fiber, 850nm, 500meter, LC connector;	1PCS
EW-SFP-GE-SD1310	1.25G, Single-mode Dual Fiber, 1310nm, 20km, LC connector;	1PCS
EW-SFP-GE-T1310	1.25G, Single-mode single Fiber, 20km, LC connector,	1PAIR
EW-SFP-GE-R1550	Tx1310/Rx1550nm : 1310nm is transmitter, 1550nm is receiver.	
EW-SFP-10G-MD850	SFP+, 10G, Multi-mode Dual Fiber, 850nm, 300meter, LC connector;	1PCS
EW-SFP-10G-SD1310	SFP+, 10G, Single-mode Dual Fiber, 1310nm, 10km, LC connector;	1PCS
EW-SFP-GFE	1.25G, SFP port transform to 10/100/1000M * RJ45 port	1PCS